

SM2340D-PLS2		
Continuous Torque	4.88	in-lb
	78	oz-in
	0.55	N-m
Peak Torque	8.04	in-lb
	129	oz-in
	0.91	N-m
Nominal Continuous Power	253	Watt
No Load Speed	5,300	RPM
Continuous Current @ Nominal Power	7.5	Amps
Voltage Constant	10.26	V/kRPM
Winding Resistance	1.0	ohms
Encoder Resolution	4,000	Counts/Rev
Rotor Inertia	0.00362	oz-in-sec ²
	2.557	10 ⁻⁶ Kg-m ²
Weight	2.8	lb
	1.27	kg
Shaft Diameter	0.250	in
	6.35	mm
Shaft, Radial Load	7	lb
	3.18	kg
Shaft, Axial Thrust Load	3	lb
	1.36	kg
EtherNet Available		
DeviceNet Available	Yes*	
ProfiBus Available	Yes*	
CanOpen Available		

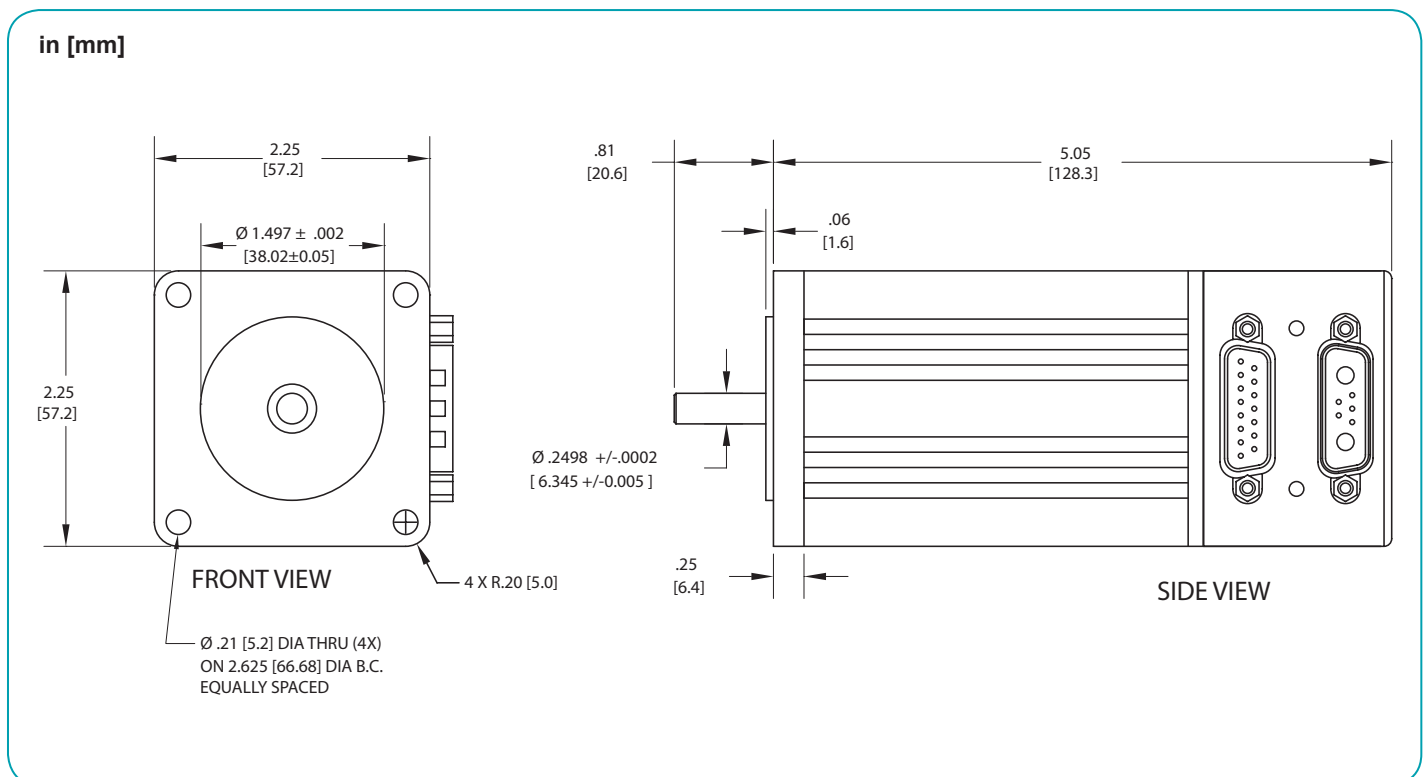

*Note: These options are only available for PLS firmware, not PLS2 firmware

Animatics SmartMotor SM2340D-PLS2 (No Options) CAD Drawing



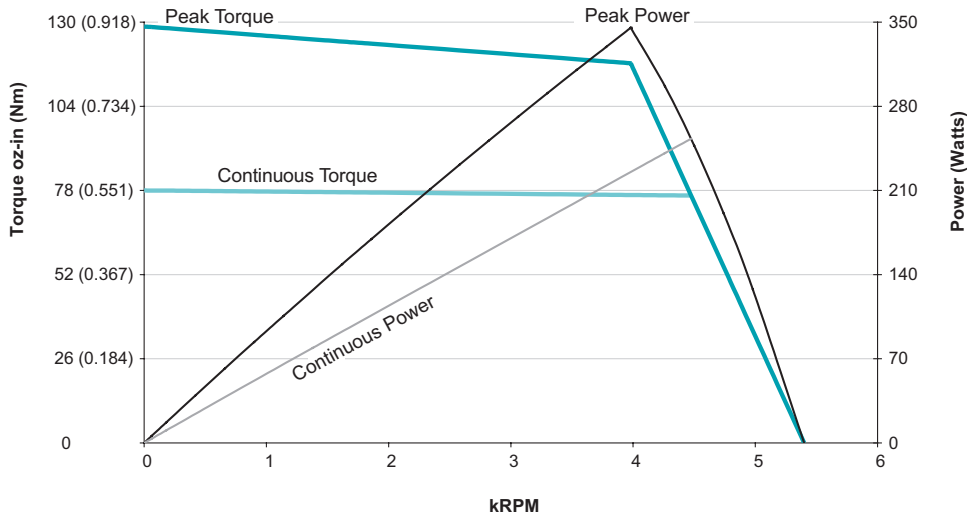

**SM2340D-PLS2
at 48 VDC
at rise to 85°C**

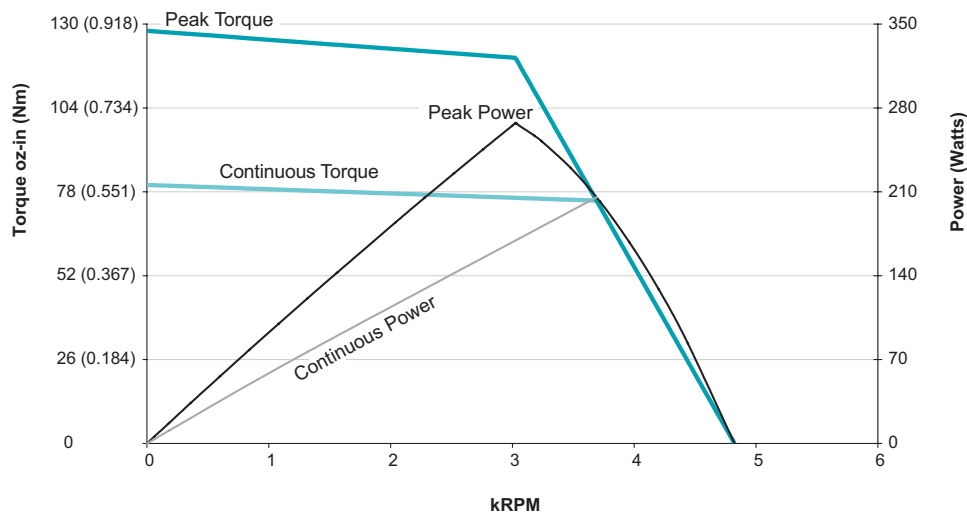

**SM2340D-PLS2
at 42 VDC
at rise to 85°C**

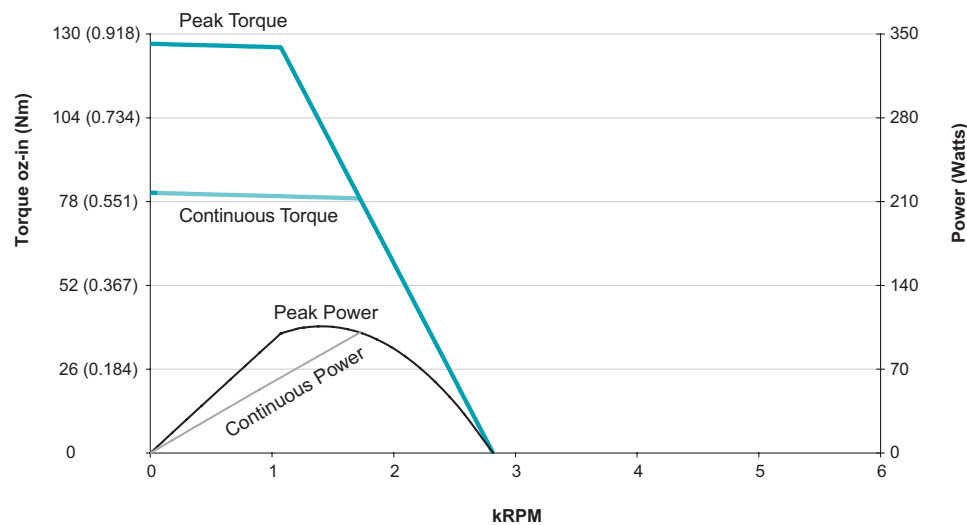

**SM2340D-PLS2
at 24 VDC
at rise to 85°C**