

SM2337D-PLS2		
Continuous Torque	2.86	in-lb
	46	oz-in
	0.32	N-m
Peak Torque	5.00	in-lb
	80	oz-in
	0.57	N-m
Nominal Continuous Power	191	Watt
No Load Speed	8,000	RPM
Continuous Current @ Nominal Power	5.6	Amps
Voltage Constant	5.62	V/kRPM
Winding Resistance	0.6	ohms
Encoder Resolution	4,000	Counts/Rev
Rotor Inertia	0.0019	oz-in-sec ²
	1.342	10 ⁻⁶ Kg-m ²
Weight	2.1	lb
	0.95	kg
Shaft Diameter	0.250	in
	6.35	mm
Shaft, Radial Load	7	lb
	3.18	kg
Shaft, Axial Thrust Load	3	lb
	1.36	kg
EtherNet Available		
DeviceNet Available	Yes*	
ProfiBus Available	Yes*	
CanOpen Available		

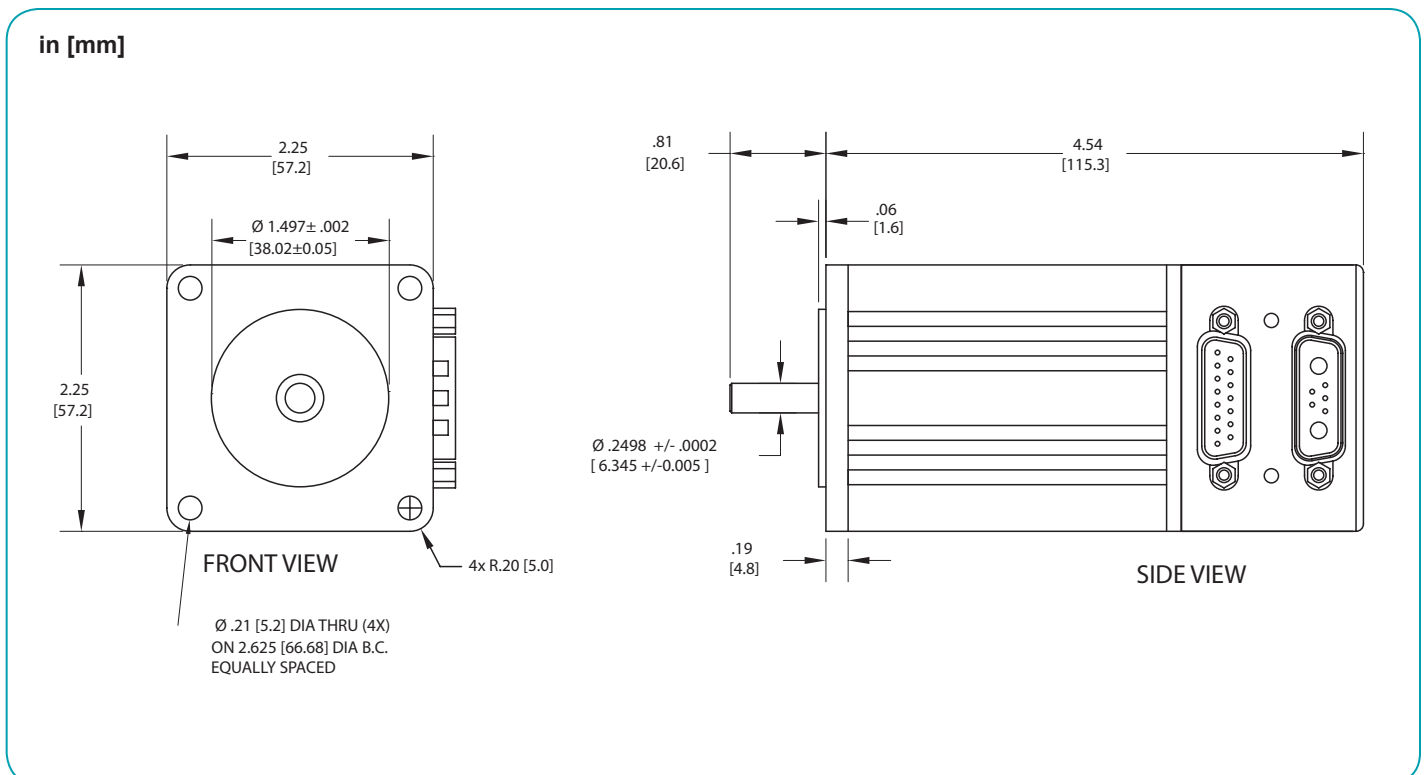

*Note: These options are only available for PLS firmware, not PLS2 firmware

Animatics SmartMotor SM2337D-PLS2 (No Options) CAD Drawing



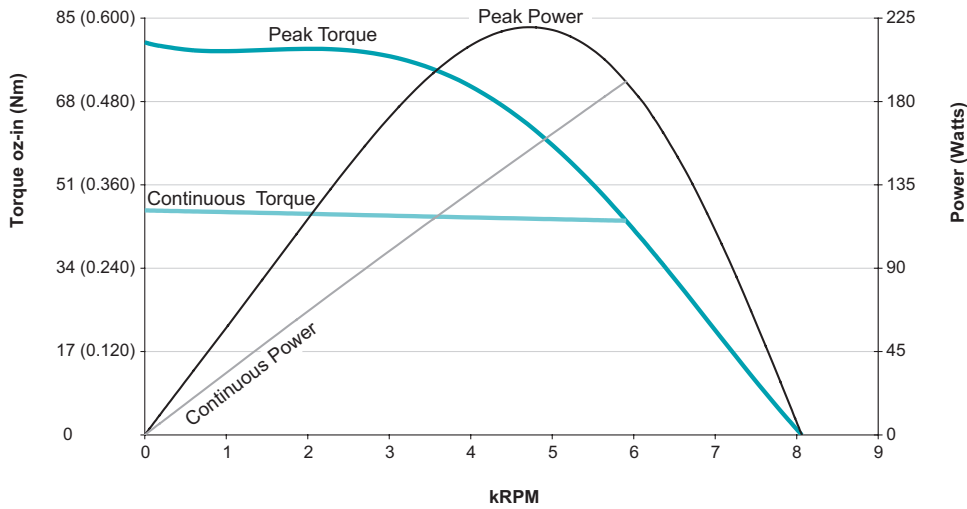

**SM2337D-PLS2
at 48 VDC
at rise to 85°C**

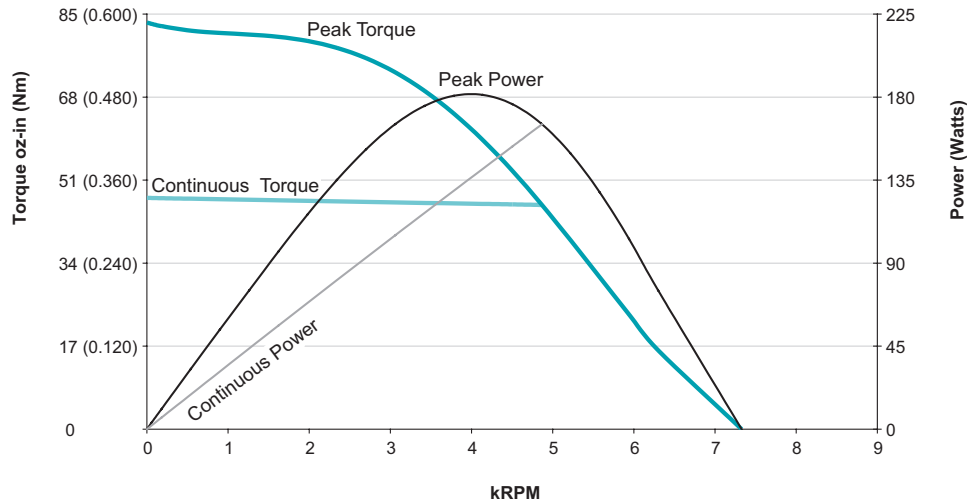

**SM2337D-PLS2
at 42 VDC
at rise to 85°C**

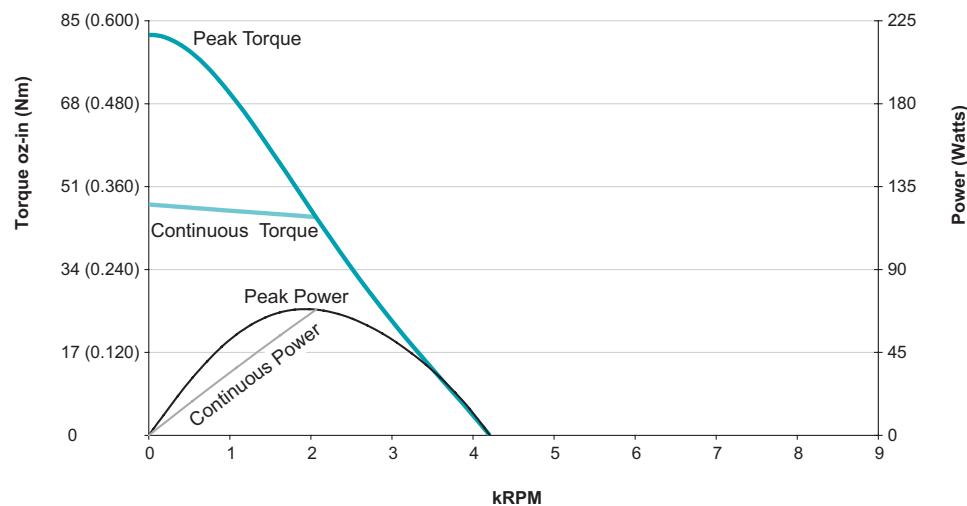

**SM2337D-PLS2
at 24 VDC
at rise to 85°C**